

CONCEPT Air Line Filter CALF

INDUSTRIAL HIGH EFFICIENCY FILTERS



Features :

- Low Pressure Drops-Assuring high energy savings.
- High capability of retention (99.999%).
- Extremely purified reservoir allow large condensate volume.
- Large capacity reservoir allow large condensate volume. Drainage layer.
- The closure provided by seal cannot be opened while filter is under pressure.
- Inlet Air Temperature 100°C (Max.).
- Filtration Grades as per ISO8573-1.
- DP Gauge (Optional).
- Auto Drain (Optional).
- MWP 16 Kg/cm² (optional 40 Kg/cm²)
- Housing - MS/CS (As per customer requirement).

FILTER MODEL	FLOW		IN/OUT Connection	DRAIN Connection	DIMENSION IN MM						ELEMENT LENGTH	'O' RING SIZE	NO. OF ELEMENT	ELEMENT CODE
	CFM	M ³ /Hr			A	B	C	D	E (ID)	F (OD)				
CALF - 0600	600	1038	2" BSP (F)	½" BSP (F)	285	135	850	400	156	276	350	190x5.3 mm	1	ELCA600100X350
CALF - 0800	800	1384	2-1/2" BSP (F)	½" BSP (F)	305	144	1000	550	156	276	500	190x5.3 mm	1	ELCA800095X500
CALF - 1000	1000	1730	3" BSP (F)	½" BSP (F)	394	148	875	400	208	342	350	235x5.3 mm	2	ELCA500095X350
CALF - 1500	1500	2595	3" BSP (F)	½" BSP (F)	444	159	950	400	270	406	350	291x5.3 mm	3	ELCA500095X350
CALF - 1500	1500	2595	4" FLANGE (FL)	½" BSP (F)	458	159	950	400	270	406	350	291x5.3 mm	3	ELCA500095X350
CALF - 2000	2000	3460	4" FLANGE (FL)	½" BSP (F)	458	162	1025	550	270	406	500	291x5.3 mm	3	ELCA800095X500

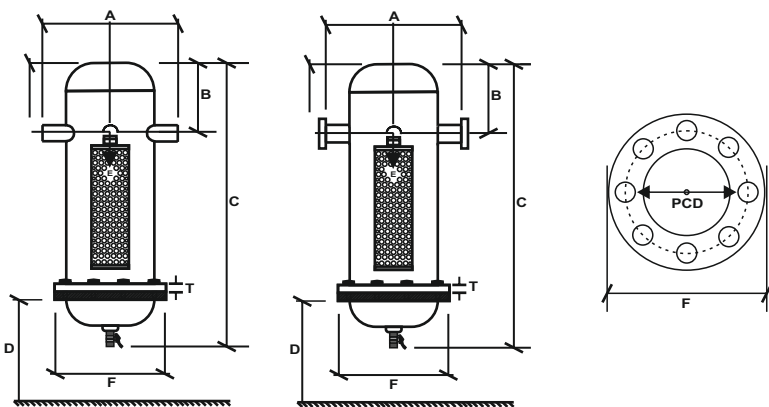

CFM	F	(PCD) D	T	HOLE	NO.
600	280	242	23.9	22.22	8
800	280	242	23.9	22.22	8
1000	345	298	27	22.23	8
1500	405	362	28.6	25.4	12
2000	405	362	28.6	25.4	12

All dimension are in mm

FLANGE DETAILS

(As per ANSI-B16.5/Class150)

NP5	CFM	(O)	(PCD) (W)	TF	HOLE (D)	NO.
10"	1500 F	236	190.5	22.3	19.05	8
10"	2000 F	230	190.5	22.3	19.05	8

All dimension are in mm



CONCEPT TECHNOSTRUCTURES

Horizon Tower, 504, 5th Floor, J.L.N. Marg, Jaipur - 302017, India

M. No.: +91- 8875009534, 9799917442

Tel. No.+91- 0141-4981363

Email : sales@conceptgroups.com / conceptsalesjpr@conceptgroups.com

conceptjpr@conceptgroups.com

Website : www.conceptgroups.com

Certificate Number:
114629A/0001/UK/En
ISO 9001:2015



CONCEPT
CALF/CAMS - R-01
CATCALFX11241