

Amogh-dd-23

MICRO CONTROLLER AUTO DRAIN



TECHNICAL SPECIFICATION

Display : 3 Digit 7 Segment LED
 Supply : 110 V AC/230 V AC, 50Hz (Please Specify)
 Range : ONTIME (0-999 S/M/H (Factory set 1-9 Sec.)
OFF Time : 0-999 S/M/H (Factory set 99.9 Min.)

INDICATIONS (LED)

S : Set time in Seconds
 M : Set time in Minute
 H : Set time in Hours
 ON : Valve ON

Enclosure : Polycarbonate with IP65 (Weather Proof)
 Valve : Aluminum / Brass / SS 304 / SS 316 (As per requirement)
 Working Pressure : 12 Kg/cm² / 16 Kg/cm² / 40 Kg/cm² / 70 Kg/cm²
 Connection : 1/4"/1/2"/3/4"/1" BSP (F) or NPT (F) (On Demand)

MENU 1

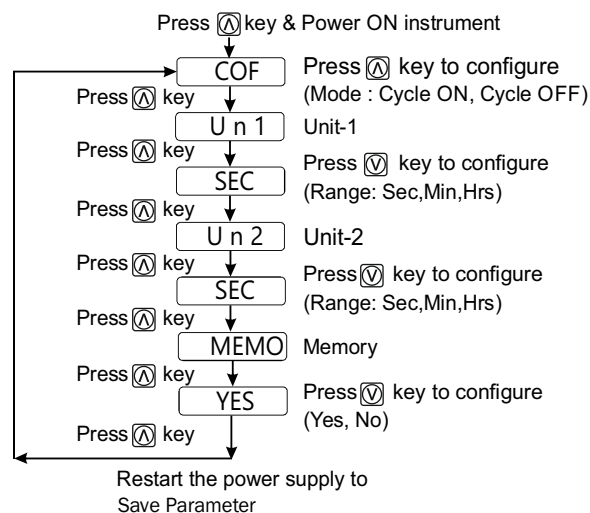

MENU 2

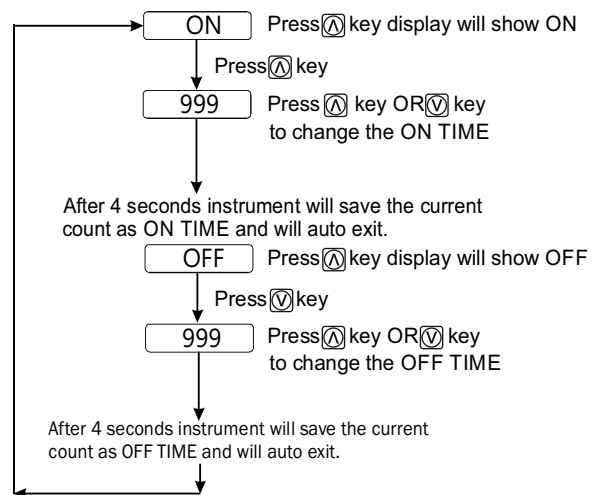

DIP SWITCH SETTING

Use Dip switch to configure SWITCH 1, SWITCH 2, SWITCH 3 & SWITCH 4 for DP Selection.

ON TIME		
SWITCH-1	SWITCH-2	RANGE
ON	ON	999
ON	OFF	99.9
OFF	ON	9.99
OFF	OFF	.999

OFF TIME		
SWITCH-3	SWITCH-4	RANGE
ON	ON	999
ON	OFF	99.9
OFF	ON	9.99
OFF	OFF	.999

For Example, If we want to configure the timer like on time 99.9 seconds & off time 999 Min. Set the DIP switches as shown in figure.

WP	ORIFICE (in mm)
12	5.0/4.0
16	2.5
40	1.3
70	0.9

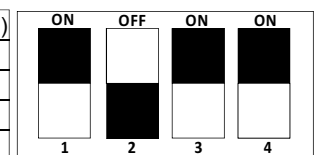

Model Selection
Amogh-d23
 MCD

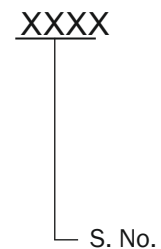
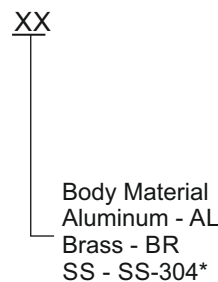
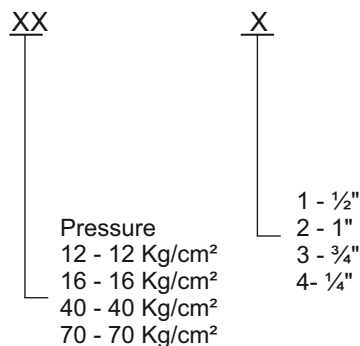

* SS-316 Available on request



CONCEPT TECHNOSTRUCTURES

Horizon Tower, 504, 5th Floor, J.L.N. Marg, Jaipur - 302017, India
 M. No.: +91- 8875009534, 9799917442
 Tel. No.+91- 0141-4981363
 Email : sales@conceptgroups.com / conceptsalesjpr@conceptgroups.com
 conceptjpr@conceptgroups.com
 Website : www.conceptgroups.com

Certificate Number:
 114629/A/0001/UK/En
 ISO 9001:2015



CONCEPT
 MD - R-01

CATAMDD2311241